

7SG163 Ohmega 300 Series

7SG163 Protection Relay

Document Release History

This document is issue 2010/02. The list of revisions up to and including this issue is:
Pre release

2010/02	Document reformat due to rebrand

The copyright and other intellectual property rights in this document, and in any model or article produced from it (and including any registered or unregistered design rights) are the property of Siemens Protection Devices Limited. No part of this document shall be reproduced or modified or stored in another form, in any data retrieval system, without the permission of Siemens Protection Devices Limited, nor shall any model or article be reproduced from this document unless Siemens Protection Devices Limited consent.

While the information and guidance given in this document is believed to be correct, no liability shall be accepted for any loss or damage caused by any error or omission, whether such error or omission is the result of negligence or any other cause. Any and all such liability is disclaimed.

Contents

1	Introduction	3
1.1	Auto-reclose	3
1.2	Check Synchronisation	3
2	Description of Operation	4
2.1	Analogue Inputs	4
2.2	Status Inputs	4
2.3	Relay Outputs	4
2.4	Auto-reclose Sequence	4
2.5	Synchronising Conditions	6
2.6	Metering	10
3	Performance Specification	11
3.1	Accuracy	11
3.2	Accuracy General	11
3.3	Accuracy Influencing Factors	11

1 Introduction

1.1 Auto-reclose

Auto-reclose is commonly applied to Transmission and Distribution systems. Statistically, the majority of system faults are of a transient nature so that once the fault has been cleared by the protection, the faulted circuit can be re-energised with a likelihood of minimal disturbance to the rest of the system. An important feature of overhead line faults is that since air is the main insulant a significant majority of flash-overs cause no permanent damage to the circuits and about 88% of fault clearances can be quickly followed by the circuits return to service by operation of automatic switching and reclosing facilities.

The single-shot auto-reclose sequence provided is shown in the diagram below;

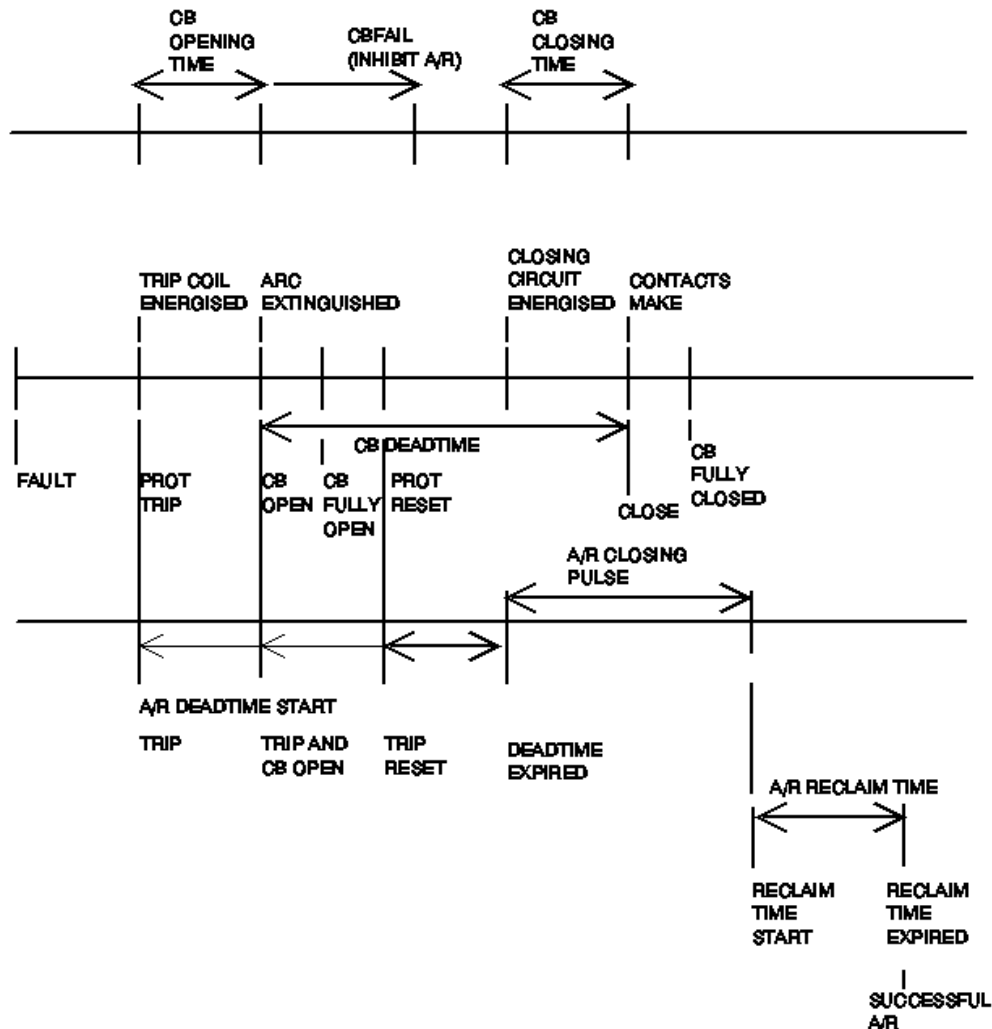

Figure 1 – Auto-reclose Sequence

1.2 Check Synchronisation

When two power systems are to be connected together it is essential that the systems either side of the breaker be reasonably in synchronism. Quantities such as the voltage magnitudes, the system frequencies and the relative phase angles of the two systems are acceptable before an attempt is made to connect. Closing the circuit breaker without due care and attention to some or all of these quantities can cause undue stresses to the system. The Check and System synchronising function measures single phase voltage quantities at each side of the CB and will only permit a CB close when the two systems fall within the relay setting parameters.

2 Description of Operation

2.1 Analogue Inputs

The relay compares the voltage on either side of the breaker. The line side voltage is taken from the phase B voltage input. On the busbar side, the reference voltage is taken from the busbar VT, and may be connected either between the B phase and earth or between phase A and phase B. This busbar voltage is applied to inputs E21 and E22.

2.2 Status Inputs

The Ohmega relay can be supplied with up to 27 user configurable Status inputs. Any of these inputs can be assigned to one or more standard functions. These functions include circuit breaker status, Autorecloser in and out of service, external triggering, blocking and lockout functions.

2.3 Relay Outputs

The Ohmega relay can be supplied with up to 29 user configurable Outputs. Any of these output contacts can be assigned to one or more standard functions. These functions include circuit breaker close pulse, circuit breaker position, AR in/out of service and circuit breaker failure.

2.4 Auto-reclose Sequence

The relay incorporates a number of safeguards to prevent mal-operation of the auto-reclose system. The relay tends to err on the side of not closing, since the operational consequences of a failure to reclose are generally less onerous, than those for an unwanted reclosure.

The status of the Auto-reclose sequence can be monitored in the Instruments Menu, using the Auto-reclose State Instrument

2.4.1 In/Out Switching

The auto-reclose in/out of service switching is controlled using two status inputs defined as AR IN and AR OUT. The A/R feature may be switched out of service in one of two ways. Either via the HMI (from the front panel or via a pc over a communication link) or by an A/R OUT status input. A/R OUT status input has priority over A/R IN. If both are raised the relay will be in Out Of Service. Once the relay has been switched Out Of Service the reverse action A/R IN is required before the relay will go back In Service. The A/R In Status Input is positive edge triggered. Initially, with the autorecloser in service, but not started, the autoreclose state instrument will display IDLE.

2.4.2 CB in Service/CB Memory

This is used with the Live Line Check functionality. If the Line voltage was "dead" for 2 seconds prior to tripping – CB maintenance condition - the ARC functionality is disabled. This prevents auto-reclosing when the line is normally de-energised or normally open.

2.4.3 Auto-reclose Initiation

If the CB is in service and the Autorecloser is in service, the Auto-reclose system will be initiated by:

- 1P or 2P Zone 1 earth or phase fault
- A 1P or 2P carrier aided trip
- Energisation of the Trip and Reclose status input.

The autoreclose can be set to start for the following additional fault types:

- 3P Zone 1 trip
- 3P carrier aided trip
- Zone 2
- Zone 3
- Directional Earth Fault
- Directional Earth Fault carrier aided trip

The Autoreclose will not start for any trip when the Block Auto-reclose status input is energised. Under these conditions, the autorecloser will remain in IDLE mode. It will not go to lockout, but no Auto-reclose operation will be started.

The relay will go direct to Lockout if the following faults occur:

- Switch-On-To-Fault.

2.4.4 Dead Time.

Once the cycle has been initiated, the relay will check that the protection and the circuit breaker have operated correctly, before the dead time delay starts. The relay uses three criteria to check this;

- The circuit breaker has opened (status taken from CB Auxiliary contacts)
- Trip initiation has been removed
- Line voltage has gone to zero (Live Line check).

Where VT on the line side of the circuit breaker are not available, the live line check should be disabled. A timer called the Sequence Fail Timer supervises this process. If the relay does not see all these events occur between the trip initiation and the end of the Sequence Fail Timer, the relay will Lockout.

Once the dead time has been successfully started, the relay will wait for the dead time to expire. If, during the dead time, the relay detects that the CB has closed (due to an external source) it increments its reclose count and advances to the next part of the reclose sequence (begin reclaim time).

2.4.5 Closing Conditions.

Once the dead time has expired, the relay will check the closing conditions, which may be set as a combination of the following options;

- Dead Bar Charge – Busbar voltage is “dead” with Line “live”
- Dead Line Charge – Line voltage is “dead” with Bus “live”
- Dead Line & Dead Bar Close – Both line and bus are “dead”
- Check Sync Close – Both line and bus are “live”
- Unconditional Close – Close regardless of bus and line voltage.

The checking of these conditions will take approximately 2 seconds. A timer known as the Sync Close Delay is started at the end of the dead time. If the synchronising conditions are not met within this time, the relay will go to lockout. For more detail on the synchronising system see part 2.5 of this section.

The Auto-reclose State Instrument will indicate CLOSE INHIBIT while the relay checks the close conditions are being evaluated.

If the specified conditions are met within the sync close delay, the relay will issue a close pulse. The Auto-reclose State instrument will indicate CLOSE PULSE. This contact will remain closed for the duration of the CB Close Pulse width. If the CB has not closed by the end of this time delay, the relay will go to lockout, and operate the CB Fail to Close alarm. If the relay trips during the close pulse the relay will lockout and operate the Close onto Fault output.

2.4.6 Reclaim Time.

After the close pulse has been issued, the reclaim time is started. The Auto-reclose state instrument will indicate RECLAIM TIME. After the breaker recloses once of two things will occur. Either the reclose will be successful and the fault will be removed from the system, or it will fail and the relay will trip and lockout the auto-recloser

If the auto-reclose cycle is successful, and the transient fault has been removed, the relay will reset the Auto-reclose cycle at the end of the reclaim time. The Auto-reclose state instrument will return to IDLE.

2.4.7 Block Auto-reclose.

Energisation of the block Auto-reclose status input will pause the Auto-reclose sequence. All timers currently active will be paused until the input is de-energised. Another timer, defined as the reclose blocked delay will start when this status input is energised, and if it remains energised for longer than this delay, the relay will go into lockout.

Note that block Auto-reclose and Auto-reclose lockout are not the same thing. A block is applied for a condition in which it may not be safe to reclose at that time, but the situation may recover.

2.4.8 Auto-reclose Lockout.

The Lockout state can be reached for a number of reasons as described in the preceding sections. Once the Lockout condition has been reached, it will be maintained until reset. Lockout will normally be reset when the circuit breaker is successfully closed. Alternatively, if required it can be reset after a time delay (by enabling Reset Lockout by timer in the Auto-reclose menu) or via the Reset Lockout status input (provided there is no signal present which will cause Lockout).

The Lockout condition has a delayed drop-off of 2s. Lockout does not issue a trip signal.

Lockout indicates an abnormal system occurrence, an event that needs to be investigated. When a CB is normally open the A/R relay does not go to Lockout, but A/R sequences are prevented by using a combination of Trip and CB In Service to start the sequence.

2.5 Synchronising Conditions

The Check and System Synchronising function measures single phase voltage quantities on each side of the CB and will only permit a CB close when the two systems fall within predefined limits. The following section describes the various criteria used to determine whether or not to issue a close pulse to the breaker, during an auto-reclose or a manual close operation. Those criteria are summarised in the diagram below;

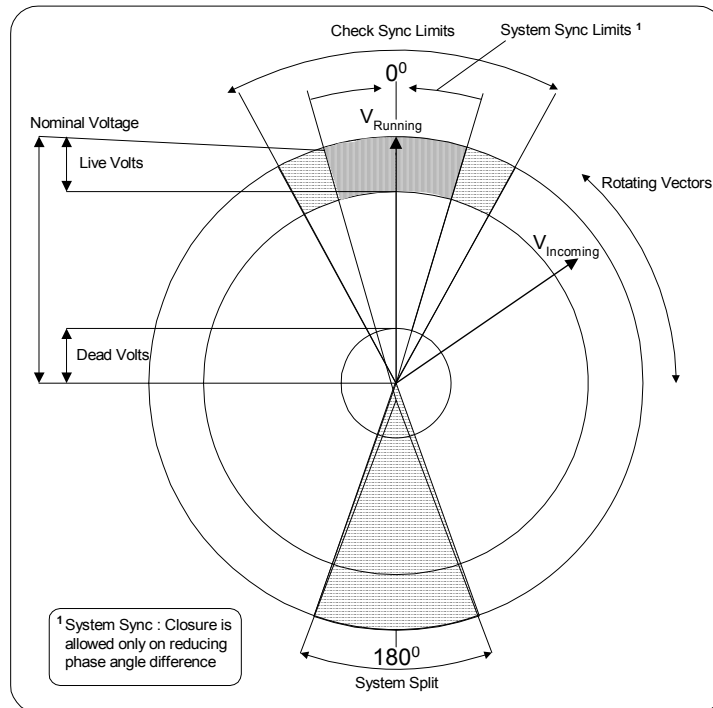

Figure 2 - Check and System Synchronising

2.5.1 Phase angle and frequency monitoring elements

The relay will monitor the angle between the line and busbar voltages, as long as those voltage are greater than 5V. The relay has two synchronising modes, System Sync and Check Sync. When the synchronism is being evaluated, if the angle between bus and line voltage is less than the Split Angle, the relay will use the Check Sync settings. If this angle increases above the Split Angle setting, the relay will use the System Sync settings, and will only allow a close if the phase angle between the two signals is decreasing.

2.5.2 Voltage monitoring elements

2.5.2.1 Undervoltage detectors

The undervoltage detectors, if enabled, can block a close output command if either the line voltage or the bus voltage is below the undervoltage setting value. Both line and bus have their own independent settings.

2.5.2.2 Differential voltage detectors

The differential voltage detector, if enabled, can block a close output command if the difference between the line and bus voltages is greater than the differential voltage setting value.

2.5.2.3 Voltage detectors

Voltage detectors determine the status of the line or bus. If the voltages on either the line or bus are below a set threshold level they can be considered to be 'dead'. If the voltages are within a setting band around the nominal voltage they are classed as 'live'. Independent voltage detectors are provided for both line and bus.

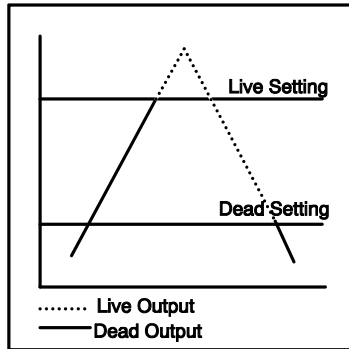

If a voltage is in the dead band range then it will be classed as dead until it has reached the live band area. Similarly, if a voltage is live, it continues to be live until it has reached the dead band area. This effectively allows for variable amounts of hysteresis to be set. Figure 3 illustrates the voltage detector operation.

Note : the area between the dead and live zones is not indeterminate. When any voltage is applied to the relay it will ramp up the software RMS algorithm and always pass through the dead zone first.

Figure 3 – Voltage Detector Operation

Although a wide range is provided for live and dead voltage detector levels, these must not overlap. The relay software acts to prevent this from happening and this is to stop unusual alarm outputs and conflicts with internal logic elements. If the user attempts to increment the dead voltage level to the live voltage level, the relay will not accept the setting. Similarly, if the live level decrements to the dead level, the setting will not be allowed. The two voltages are displayed simultaneously on the LCD display so that this operation is clear to the user.

2.5.3 Sync Override Feature

For certain switching operations, a means of bypassing the Check Synchronisation function is provided, via two status inputs. This is provided with a separate Sync Override and a separate Manual Sync Override.

2.5.4 Check Synchronising Mode

For the relay to issue a CheckSync Close the following conditions have to be met :

CHECK SYNC ANGLE – the phase difference between the line and bus voltages has to be less than the phase angle setting value. Whilst within the limits the phase angle can be increasing or decreasing and the element will still issue a valid close signal.

CHECK SYNC SLIP – the frequency difference between line and bus has to be less than the slip frequency setting value.

CHECK SYNC TIMER – the phase angle and voltage blocking features have to be within their parameters for the length of the slip timer setting. If either the phase angle or the voltage elements fall outside of their limits the slip timer is reset. If they subsequently come back in then the slip timer has to time out before an output is given. (This ensures that a close output will not be given if there is a transient disturbance on the system due to e.g. some remote switching operations).

LINE U/V DETECTOR – the line voltage has to be above the line undervoltage setting value and also above 5V for an output to be given.

BUS U/V DETECTOR – the bus voltage has to be above the bus undervoltage setting value and also above 5V for an output to be given.

DIFFERENTIAL VOLTAGE DETECTOR – the difference between the line and bus voltages has to be less than the ΔV detector setting value for an output to be given.

The relay is always started in Check Synchronising mode of operation. To proceed to System Synchronisation a system split must occur.

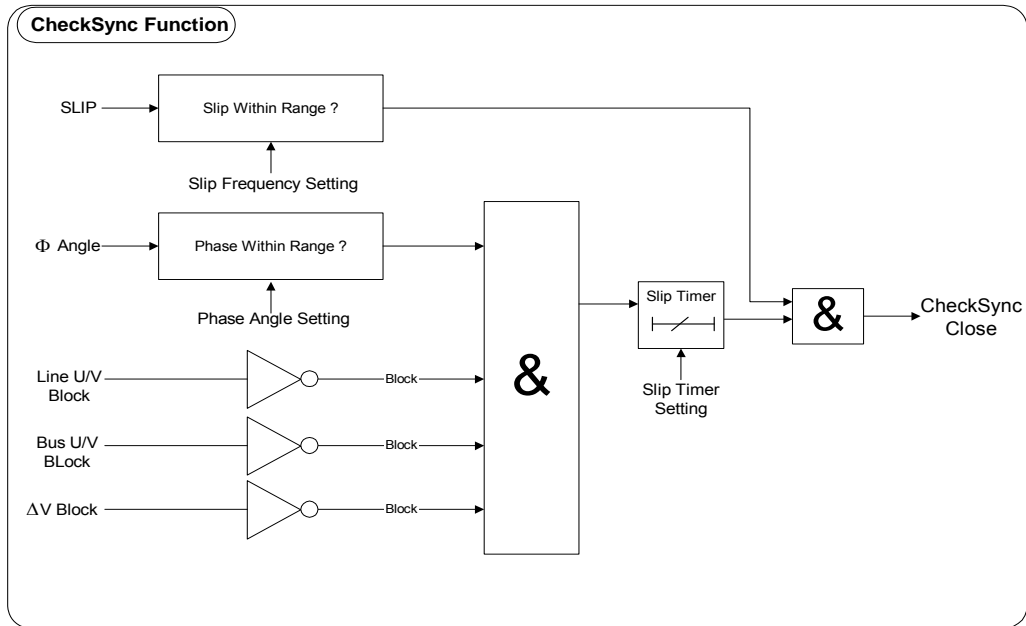

Figure 4 - Check Sync Function

2.5.5 Manual Sync Override Feature

If manual closes are required to be carried out via an operator, these will be performed with Check Synchronisation unless the Manual Sync Override input is energised.

2.5.6 System Split Detector

A system split occurs where there is a loosely tied or non-parallel circuits on a power system. Under these conditions the frequencies of the voltages either side of the breaker are asynchronous and therefore high phase angle differences can occur as the frequencies slip past each other. The system split detector operates when the phase angle difference exceeds a pre-set value. The setting range for a system split is from 90°-175° step 1°.

Note : the system split setting is effectively an absolute value and therefore a split will occur at the value regardless of the direction of the frequency slip e.g. if an angle of 170° is selected, then starting from 0°, a split will occur at +170° or -170° (effectively +190°).

If a system split occurs during a CheckSync operation the following events occur :

- The CheckSync function is inhibited.
- The SystemSync function is started if the setting has been set to A/R Split Action SYSTEM SYNC. If the A/R Split Action has been set to LOCKOUT, then, a system split LED indication is given. The relay will stay in this lockout mode until one of the following methods of resetting it is performed:
 - 1) The relay is reset from Lockout.
 - 2) A status input command is received.
 - 3) An appropriate IEC870 comms. Command is received.
- An event is recorded.
- The split flag can be mapped to an output relay for alarm indication.
- The system split LED will stay on for a minimum time, or can be latched using non self reset LEDs.

2.5.7 System Synchronising Mode

For the relay to issue a SystemSync Close the following conditions have to be met :

SYSTEM SYNC ANGLE – the phase difference between the line and bus voltages has to be less than the phase angle setting value and the phase angle has to be decreasing before the element will issue a valid close signal.

SYSTEM SYNC SLIP – the frequency difference between line and bus has to be less than the slip frequency setting value.

SYSTEM SYNC TIMER – the phase angle and voltage blocking features have to be within their parameters for the length of the slip timer setting. If either the phase angle or the voltage elements fall outside of their limits the slip timer is reset. If they subsequently come back in then the slip timer has to time out before an output is given. (This ensures that a close output will not be given if there is a transient disturbance on the system due to e.g. some remote switching operations).

LINE U/V DETECTOR – the line voltage has to be above the line undervoltage setting value and also above 5V for an output to be given.

BUS U/V DETECTOR – the bus voltage has to be above the line undervoltage setting value and also above 5V for an output to be given.

DIFFERENTIAL VOLTAGE DETECTOR – the difference between the line and bus voltages has to be less than the ΔV detector setting value for an output to be given.

Once a System Split has been detected, the settings A/R SPLIT ACTION and MC SPLIT ACTION define the conditions which must be met for closing to occur;

LOCKOUT : the relay will go into lockout mode and no closure is attempted.

CHECK SYNC: the relay will issue a Check Sync Close automatically if the relevant parameters are met.

SYSTEM SYNC: the relay will issue a System Sync Close automatically if the relevant parameters are met.

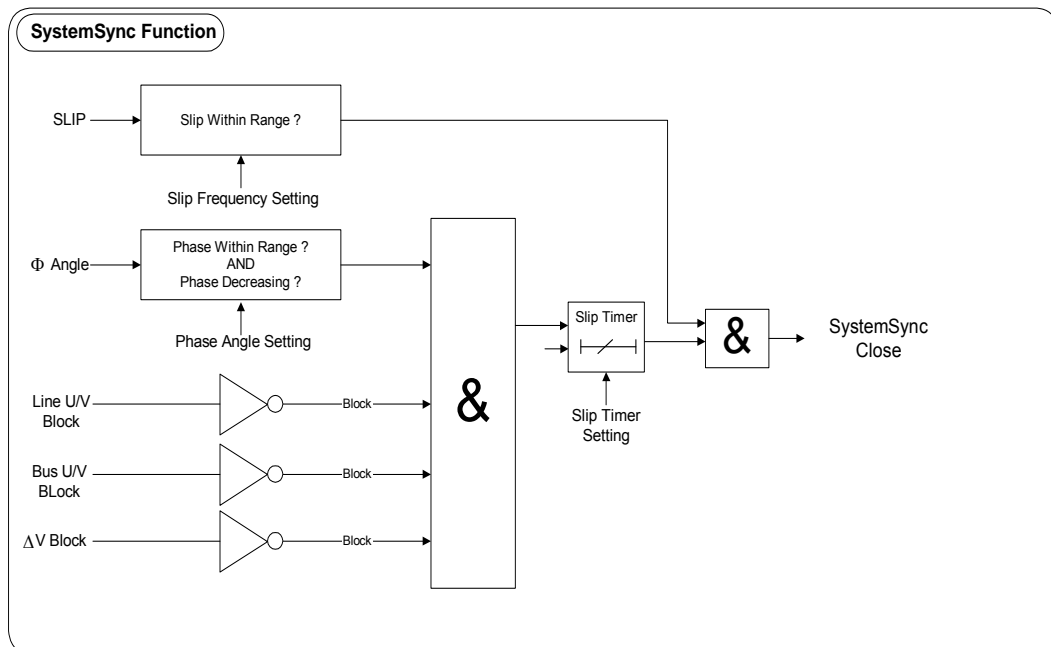

Figure 5 - System Sync Function

2.6 Metering

The metering feature provides real-time data available from the relay fascia in the 'Instruments Mode' or via the communications interface. The following displays are available :

- Phase difference between Line and Bus
- Frequency of both Line and Bus
- Frequency slip between Line and Bus
- RMS volts for both Line and Bus
- Voltage Differential between line and Bus
- Total Number of CB Closes
- Delta Number of CB Closes
- A/R Sequence Shot Number
- A/R State

Note : while the instrument displays are updated as often as the software routines can service them, some have their response time deliberately slowed down to enable them to be read.

3 Performance Specification

3.1 Accuracy

CS and SS Phase Angle measurement	
Operate	Setting $-3^{\circ} + 0^{\circ}$
Reset	operate value $-0^{\circ} + 3^{\circ}$
CS and SS Slip Frequency	
Operate	Setting $-15\text{mHz} + 0\text{mHz}$
Reset	operate value $-0\text{mHz} + 15\text{mHz}$
Split Detector measurement	
Operate	setting $\pm 1.5^{\circ}$
Reset	detector is latched
Line and Bus Voltage Detector Elements	
Live Operate	setting $\pm 1\%$
Live Reset	dead operate setting $\pm 1\%$
Dead Operate	setting $\pm 1\%$
Dead Reset	live operate setting $\pm 1\%$
Line and Bus U/V Detector Elements	
Operate	Setting $\pm 1\%$
Reset	$< 104\%$ of operate value
□V Detector Element	
Operate	Setting $\pm 2\%$ or 0.5V whichever is greater
Reset	Typically $> 90\%$ (and always within 2V) of operate value
All Timers	
Timing Accuracy	$\pm 1\%$ or 10ms

3.2 Accuracy General

Measuring Accuracy

Voltage	$\pm 1\%$ (for range $7\text{V}-132\text{Vrms}$)
Frequency	Typically $\pm 10\text{mHz}$
Phase	Typically $\pm 1^{\circ}$

3.3 Accuracy Influencing Factors

Temperature

Ambient Range	-10°C to $+55^{\circ}\text{C}$
Variation over range	$\leq 5\%$

Frequency

Range	47Hz to 51Hz 57Hz to 61Hz
Setting variation	$\leq 1\%$
Phase Angle Measurement	$\leq 1\%$
Operating time variation	$\leq 1\%$